



# Specifier Guide



# TRIFORCE<sup>®</sup>

OPEN JOIST



# TRIFORCE® Specifier Guide

May 11, 2023 - U.S. Edition

This guide is intended to provide general information for designers, general contractors and end-users. It is designed for loads that are uniformly distributed over joists with end bearings (minimum end bearing length is 1½"). For loads that are not uniformly distributed and/or for joists supported by bearings other than end bearings, joist capacity must be verified using the manufacturer's Analyzer software. Application of the contents of this guide is the responsibility of the designer and/or general contractor. For further information or assistance, contact a Barrette Structural Distribution representative.

In keeping with its ongoing commitment to product development, Barrette Structural Distribution periodically updates its literature. Please visit our website ([www.openjoisttriforce.com](http://www.openjoisttriforce.com)) to confirm that this version is the most recent.



[www.openjoisttriforce.com](http://www.openjoisttriforce.com)  
[info@ojtriforce.com](mailto:info@ojtriforce.com)

## Evaluation Reports

### U.S. Reports

ESR-2999

<https://icc-es.org/general-listing-directory/>



IAPMO UES ER 480, 539, 708  
[www.iapmoes.org/EvaluationReports](http://www.iapmoes.org/EvaluationReports)



### Intertek-approved fire-resistant assemblies

SPEC ID: 35685 Standard

<https://bpdirectory.intertek.com>

Look up "Barrette Structural Inc." in the Company field or "35685" in the Spec ID Lookup field.



### Canadian Reports

Canada • CCMC-13474-R

[www.nrc-cnrc.gc.ca](http://www.nrc-cnrc.gc.ca)



Province of Ontario • 10-02-239 (13474-R)

[www.mah.gov.on.ca](http://www.mah.gov.on.ca)

# Table of Contents

<b>4</b>	Trimable for Precision Fit
<b>4</b>	Available Joist Sizes
<b>5</b>	Joist Identification and Orientation
<b>6</b>	Maximum Allowable Spans
<b>8</b>	Maximum Allowable Live Loads
<b>10</b>	Storage and Handling
<b>11</b>	Installation Instructions
<b>12</b>	Standard Details
<b>13</b>	Rim Board Installation
<b>14</b>	Typical Blocking Detail
<b>15</b>	End To End Joists
<b>16</b>	Cantilevered Joists
<b>17</b>	Wood Beam Connections with Hangers
<b>17</b>	Steel Beam Connections with Hangers
<b>17</b>	Steel Beam Connections Without Hangers
<b>18</b>	Doubled Joist for Concentrated Side Load
<b>18</b>	Reinforcement for a Concentrated Side Load
<b>18</b>	Reinforcement for a Concentrated Top Load Between Two Bearings
<b>19</b>	Mechanical Clearances
<b>19</b>	Openings in the OSB End Panel of a Joist
<b>20</b>	Strongback Bridging
<b>21</b>	TRIFORCE® Floor System Performance
<b>22</b>	Mid-Span Strongback Bridging Table
<b>23</b>	Acoustic Performance
<b>23</b>	Fire Performance Ratings for Multifamily Buildings
<b>24</b>	Fire Performance Ratings for Multifamily Buildings
<b>25</b>	Fire Performance for Residential Buildings with Unfinished Ceilings
<b>26</b>	TRIFORCE® Analyzer Software
<b>27</b>	Single Joist Connectors
<b>28</b>	Double Joist Connectors
<b>29</b>	Warranty



## A Cost-Effective Open Design

The design of **TRIFORCE**® open joist allows professionals to quickly install plumbing, electrical and HVAC systems during or after construction— a great way to keep labor costs down!

## Fire Performance Certification

**TRIFORCE**® open joist has been certified for equivalent fire performance to 2X10 nominal dimension lumber, qualifying as an exception to the code requirement for an unfinished basement ceiling.

## Stock Product

**TRIFORCE**® open joist is make-to-stock, which helps us to keep a vast inventory so that order turnaround times can be measured in days instead of weeks or months.

## Consistent Quality

Barrette Structural Distribution has installed state-of-the-art robotic manufacturing equipment to produce **TRIFORCE**® open joist, which leads to an extremely precise product. **TRIFORCE**® open joists are individually tested. Moreover, a third-party inspection body regularly tests **TRIFORCE**® open joists, ensuring that the manufacturing process consistently delivers quality joists to the construction market.

## Field Adjustable

With a trimmable end of up to 24 inches, measuring mistakes won't slow down your projects!



## High Performance

Adding strongbacks in strategic locations increases floor system performance by distributing loads to adjacent joists. The resulting rigidity effectively dampens vibration. Strongback installation is quick and easy.

## Lighter and Safer

**TRIFORCE**<sup>®</sup> open joists avoid the use of metal plates and employ stronger finger joint connections and structural adhesives. Having no plates means that joists are lighter and avoid squeaking, framer injuries and damage to mechanical and wiring systems.

## Environmentally Friendly

The **TRIFORCE**<sup>®</sup> open joist manufacturing facility was built according to standards of Canada's forward-thinking Environmentally Conscious Manufacturing Model. The product's design and assembly processes reduce the use of wood fiber and avoid energy expenses involved in steel plate production.



# Trimmable for Precision Fit

TRIFORCE® open joists are manufactured with an OSB panel at one end. This end of the joist may be trimmed up to 24" to achieve the desired joist length for installation. Structures can be designed with the OSB end panel facing the inside or outside wall.

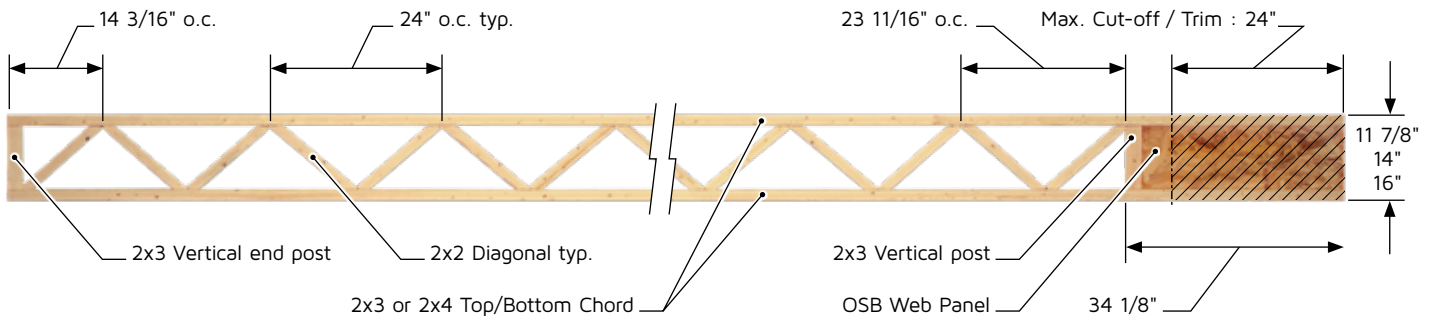

## Available Joist Sizes

TRIFORCE® open joist is produced in several depths and lengths to fulfill floor framing needs. Lengths are offered in two foot increments due to their 24" trimmability.

Depth	Series	Weight lbs/ft	Stock Lengths (feet)											
			8	10	12	14	16	18	20	22	24	26	28	30
11 7/8"	OJ314	2.80	✓	✓	✓	✓	✓							
	OJ315	2.80						✓						
	OJ415	3.35							✓					
	OJ418	3.35						S	S	✓				
14"	OJ314	2.85	✓	✓	✓	✓	✓							
	OJ315	2.85						✓	✓					
	OJ415	3.45								✓				
	OJ418	3.45							S		✓	✓		
16"	OJ314	2.95	✓	✓	✓	✓	✓							
	OJ315	2.95						✓	✓					
	OJ418	3.55							S	✓	✓	✓		
	OJ420	3.55											✓	✓

✓ = In stock

S = Limited inventory. Please contact your representative to determine quantities.

# Joist Identification and Orientation



Bottom - Bas  
Abajo **OJ418**

## Identification

**OJ418**

Grades : 14 = 1.4E  
15 = 1.5E  
18 = 1.8E  
20 = 2.0E

Flange : 3 = 2x3  
4 = 2x4

## Joist Orientation

Each TRIFORCE® open joist is marked to indicate a bottom flange. In order to achieve maximum shear capacity, the joist should be installed with proper orientation.

# Maximum Allowable Spans



Glued & Nailed Subfloor

$$\Delta L \leq L/480$$

Live Load		40 psf				40 psf				100 psf					
Dead Load		15 psf				25 psf				15 psf					
Spacing		12"	16"	19.2"	24"	12"	16"	19.2"	24"	12"	16"	19.2"	24"		
Subfloor <sup>(7)</sup>		19/32"		23/32"		19/32"		23/32"		19/32"		23/32"			
Depth	Length	Series		Maximum Floor span o.c.											
11 7/8"	8'-0"			8'-0"	8'-0"	8'-0"	8'-0"	8'-0"	8'-0"	8'-0"	8'-0"	8'-0"	8'-0"	8'-0"	8'-0"
	10'-0"			10'-0"	10'-0"	10'-0"	10'-0"	10'-0"	10'-0"	10'-0"	10'-0"	10'-0"	10'-0"	10'-0"	10'-0"
	12'-0"			12'-0"	12'-0"	12'-0"	12'-0"	12'-0"	12'-0"	12'-0"	12'-0"	12'-0"	12'-0"	12'-0"	12'-0"
	14'-0"			14'-0"	14'-0"	14'-0"	14'-0"	14'-0"	14'-0"	14'-0"	14'-0"	14'-0"	14'-0"	14'-0"	14'-0"
	16'-0"			16'-0"	16'-0"	16'-0"	14'-10"	16'-0"	16'-0"	15'-3"	-----	14'-3"	-----	-----	-----
	18'-0"	OJ315	3x2	18'-0"	18'-0"	17'-6"	<b>16'-4"</b>	18'-0"	18'-0"	16'-9"	-----	-----	-----	-----	-----
		OJ418S <sup>(9)</sup>	4x2	18'-0"	18'-0"	18'-0"	<b>18'-0"</b>	18'-0"	18'-0"	<b>18'-0"</b>	<b>18'-0"</b>	<b>17'-2"</b>	-----	-----	-----
	20'-0"	OJ415	4x2	20'-0"	20'-0"	19'-5"	<b>18'-2"</b>	20'-0"	20'-0"	<b>19'-5"</b>	-----	-----	-----	-----	-----
		OJ418S <sup>(9)</sup>	4x2	20'-0"	20'-0"	20'-0"	<b>19'-1"</b>	20'-0"	20'-0"	<b>20'-0"</b>	<b>19'-1"</b>	-----	-----	-----	-----
22'-0"	OJ418	4x2	22'-0"	21'-9"	<b>20'-6"</b>	-----	22'-0"	<b>21'-9"</b>	<b>20'-6"</b>	-----	-----	-----	-----	-----	
14"	8'-0"			8'-0"	8'-0"	8'-0"	8'-0"	8'-0"	8'-0"	8'-0"	8'-0"	8'-0"	8'-0"	8'-0"	
	10'-0"			10'-0"	10'-0"	10'-0"	10'-0"	10'-0"	10'-0"	10'-0"	10'-0"	10'-0"	10'-0"	10'-0"	
	12'-0"			12'-0"	12'-0"	12'-0"	12'-0"	12'-0"	12'-0"	12'-0"	12'-0"	12'-0"	12'-0"	12'-0"	
	14'-0"			14'-0"	14'-0"	14'-0"	14'-0"	14'-0"	14'-0"	14'-0"	14'-0"	14'-0"	14'-0"	14'-0"	
	16'-0"			16'-0"	16'-0"	16'-0"	16'-0"	16'-0"	16'-0"	16'-0"	14'-11"	16'-0"	-----	-----	
	18'-0"	OJ315	3x2	18'-0"	18'-0"	18'-0"	18'-0"	18'-0"	18'-0"	18'-0"	<b>16'-5"</b>	16'-7"	-----	-----	
	20'-0"	OJ315	3x2	20'-0"	20'-0"	19'-10"	-----	20'-0"	20'-0"	18'-5"	-----	-----	-----	-----	
		OJ418S <sup>(9)</sup>	4x2	20'-0"	20'-0"	20'-0"	<b>20'-0"</b>	20'-0"	20'-0"	20'-0"	<b>20'-0"</b>	<b>19'-6"</b>	-----	-----	
	22'-0"	OJ415	4x2	22'-0"	22'-0"	22'-0"	<b>20'-7"</b>	22'-0"	22'-0"	<b>22'-0"</b>	-----	-----	-----	-----	
	24'-0"	OJ418	4x2	24'-0"	24'-0"	23'-3"	-----	24'-0"	24'-0"	<b>23'-3"</b>	-----	-----	-----	-----	
26'-0"	26'-0"			24'-9"	-----	-----	26'-0"	<b>24'-9"</b>	-----	-----	-----	-----			

## Maximum Allowable Spans (continued)

Live Load		40 psf				40 psf				100 psf						
Dead Load		15 psf				25 psf				15 psf						
Spacing		12"	16"	19.2"	24"	12"	16"	19.2"	24"	12"	16"	19.2"	24"			
Subfloor <sup>(7)</sup>		19/32"			23/32"	19/32"			23/32"	19/32"			23/32"			
Depth	Length	Series		Maximum Floor span o.c.												
16"	8'-0"			8'-0"	8'-0"	8'-0"	8'-0"	8'-0"	8'-0"	8'-0"	8'-0"	8'-0"	8'-0"	8'-0"	8'-0"	
	10'-0"			10'-0"	10'-0"	10'-0"	10'-0"	10'-0"	10'-0"	10'-0"	10'-0"	10'-0"	10'-0"	10'-0"	<b>10'-0"</b>	
	12'-0"			12'-0"	12'-0"	12'-0"	12'-0"	12'-0"	12'-0"	12'-0"	12'-0"	12'-0"	12'-0"	<b>12'-0"</b>	<b>11'-8"</b>	
	14'-0"			14'-0"	14'-0"	14'-0"	14'-0"	14'-0"	14'-0"	14'-0"	14'-0"	14'-0"	<b>14'-0"</b>	<b>13'-4"</b>	-----	
	16'-0"			16'-0"	16'-0"	16'-0"	16'-0"	16'-0"	16'-0"	16'-0"	16'-0"	16'-0"	<b>14'-8"</b>	-----	-----	
	18'-0"	OJ315	3x2	18'-0"	18'-0"	18'-0"	18'-0"	18'-0"	18'-0"	18'-0"	18'-0"	<b>17'-9"</b>	18'-0"	<b>16'-4"</b>	-----	-----
	20'-0"	OJ315	3x2	20'-0"	20'-0"	20'-0"	19'-3"	20'-0"	20'-0"	19'-10"	-----	18'-4"	-----	-----	-----	-----
		OJ418S <sup>(9)</sup>	4x2	20'-0"	20'-0"	20'-0"	<b>20'-0"</b>	20'-0"	20'-0"	20'-0"	<b>20'-0"</b>	<b>20'-0"</b>	-----	-----	-----	-----
	22'-0"			22'-0"	22'-0"	22'-0"	<b>22'-0"</b>	22'-0"	22'-0"	<b>22'-0"</b>	<b>20'-9"</b>	<b>21'-7"</b>	-----	-----	-----	-----
	24'-0"	OJ418	4x2	24'-0"	24'-0"	24'-0"	<b>24'-0"</b>	24'-0"	24'-0"	<b>24'-0"</b>	-----	-----	-----	-----	-----	-----
	26'-0"			26'-0"	26'-0"	<b>25'-8"</b>	-----	26'-0"	<b>26'-0"</b>	<b>25'-8"</b>	-----	-----	-----	-----	-----	-----
	28'-0"			28'-0"	28'-0"	<b>26'-6"</b>	-----	28'-0"	<b>28'-0"</b>	<b>25'-11"</b>	-----	-----	-----	-----	-----	-----
30'-0"	OJ420	4x2	30'-0"	28'-2"	-----	-----	30'-0"	<b>28'-2"</b>	-----	-----	-----	-----	-----	-----	-----	

### Notes:

- The indicated spans are based on simple span joists.
- Minimum end bearing length is 1½", **spans values in bold indicate that web stiffeners are required at the OSB end panel.**
- Maximum spans are measured **centerline to centerline** of bearing and are based on uniformly loaded joists.
- Total Load deflection is limited to L/240.
- Live Load deflection is limited to **L/480**.
- The indicated spans are based on the Allowable Stress Design method as per NDS, ICC IBC/IRC code.
- The considered subfloor is a "20 oc APA rated panel" for joist's spacing of 12", 16" and 19.2" o.c. and is a "24 oc APA rated panel" for joist's spacing of 24" o.c. The subfloor must be glued as per APA Specification AFG-01 or ASTM D3498 and nailed as per NDS, ICC IBC/IRC code.
- Refer to appropriate sections of the Specifier Guide for installation guidelines and construction details.
- S** = Limited inventory. Please contact your representative to determine quantities.

# Maximum Allowable Live Loads



Glued & Nailed Subfloor

$$\Delta L \leq L/480$$

Dead Load				15 psf				25 psf				
Spacing				12"	16"	19.2"	24"	12"	16"	19.2"	24"	
Subfloor <sup>(5)</sup>				19/32"				23/32"	19/32"			23/32"
Depth	Length	Series		Maximum Live Load (psf)								
11 7/8"	8'-0"			<b>315</b>	<b>232</b>	<b>191</b>	<b>150</b>	<b>305</b>	<b>222</b>	<b>181</b>	<b>140</b>	
	10'-0"			<b>233</b>	<b>171</b>	<b>140</b>	<b>109</b>	<b>223</b>	<b>161</b>	<b>130</b>	<b>99</b>	
	12'-0"			<b>157</b>	<b>114</b>	<b>92</b>	<b>71</b>	<b>147</b>	<b>104</b>	<b>82</b>	<b>61</b>	
	14'-0"			108	79	63	48	101	69	53	----	
	16'-0"			75	57	45	----	71	47	----	----	
	18'-0"		OJ315	3x2	58	44	----	----	58	43	----	----
			OJ418S <sup>(7)</sup>	4x2	<b>89</b>	<b>68</b>	<b>58</b>	<b>47</b>	<b>89</b>	<b>68</b>	<b>58</b>	<b>45</b>
	20'-0"		OJ415	4x2	58	44	----	----	58	<b>44</b>	----	----
			OJ418S <sup>(7)</sup>	4x2	67	51	<b>43</b>	----	<b>67</b>	<b>51</b>	<b>43</b>	----
22'-0"		OJ418	4x2	52	----	----	----	52	----	----	----	
14"	8'-0"			<b>319</b>	<b>236</b>	<b>194</b>	<b>152</b>	<b>310</b>	<b>226</b>	<b>184</b>	<b>142</b>	
	10'-0"			<b>253</b>	<b>186</b>	<b>152</b>	<b>119</b>	<b>243</b>	<b>176</b>	<b>142</b>	<b>109</b>	
	12'-0"			<b>191</b>	<b>139</b>	<b>113</b>	<b>88</b>	<b>181</b>	<b>129</b>	<b>103</b>	<b>78</b>	
	14'-0"			<b>136</b>	<b>98</b>	<b>79</b>	60	<b>126</b>	<b>88</b>	<b>69</b>	50	
	16'-0"			100	71	57	42	90	61	47	----	
	18'-0"		OJ315	3x2	81	62	53	40	81	58	44	----
	20'-0"		OJ315	3x2	61	47	----	----	61	42	----	----
			OJ418S <sup>(7)</sup>	4x2	<b>95</b>	<b>72</b>	<b>61</b>	<b>50</b>	<b>95</b>	<b>72</b>	<b>58</b>	<b>41</b>
	22'-0"		OJ415	4x2	63	48	41	----	63	<b>48</b>	<b>40</b>	----
	24'-0"		OJ418	4x2	57	44	----	----	57	<b>44</b>	----	----
	26'-0"	46			----	----	----	46	----	----	----	

## Maximum Allowable Live Loads (continued)

Dead Load				15 psf				25 psf			
Spacing				12"	16"	19.2"	24"	12"	16"	19.2"	24"
Subfloor <sup>(5)</sup>				19/32"		23/32"		19/32"		23/32"	
Depth	Length	Series		Maximum Live Load (psf)							
16"	8'-0"			<b>325</b>	<b>240</b>	<b>197</b>	<b>155</b>	<b>315</b>	<b>230</b>	<b>187</b>	<b>145</b>
	10'-0"			<b>257</b>	<b>189</b>	<b>155</b>	<b>121</b>	<b>247</b>	<b>179</b>	<b>145</b>	<b>111</b>
	12'-0"			<b>211</b>	<b>155</b>	<b>126</b>	<b>98</b>	<b>201</b>	<b>145</b>	<b>116</b>	<b>88</b>
	14'-0"			<b>156</b>	<b>113</b>	<b>92</b>	<b>70</b>	<b>146</b>	<b>103</b>	<b>82</b>	<b>60</b>
	16'-0"			116	83	66	50	106	73	56	40
	18'-0"	OJ315	3x2	<b>107</b>	<b>81</b>	<b>65</b>	<b>49</b>	<b>103</b>	<b>71</b>	<b>55</b>	----
	20'-0"	OJ315	3x2	80	62	49	----	78	52	----	----
		OJ418S <sup>(7)</sup>	4x2	<b>121</b>	<b>87</b>	<b>70</b>	<b>53</b>	<b>111</b>	<b>77</b>	<b>60</b>	<b>43</b>
	22'-0"			<b>96</b>	<b>73</b>	<b>62</b>	<b>46</b>	<b>96</b>	<b>67</b>	<b>52</b>	----
	24'-0"	OJ418	4x2	<b>76</b>	<b>58</b>	<b>49</b>	<b>40</b>	<b>76</b>	<b>58</b>	<b>45</b>	----
	26'-0"			61	46	----	----	<b>61</b>	<b>46</b>	----	----
	28'-0"			54	41	----	----	<b>54</b>	<b>41</b>	----	----
30'-0"	OJ420	4x2	44	----	----	----	44	----	----	----	

### Notes:

1. The indicated loads are based on simple span joist, measured center to center of bearings.
2. Minimum end bearing length is 1½", **values in bold indicate that web stiffeners are required at the OSB end panel.**
3. Live Load deflection is limited to **L/480** and Total Load deflection is limited to L/240.
4. The indicated load are based on the Allowable Stress Design method as per NDS, ICC IBC/IRC code.
5. The considered subfloor is a "20 oc APA rated panel" for joist's spacing of 12", 16" and 19.2" o.c. and is a "24 oc APA rated panel" for joist's spacing of 24" o.c. The subfloor must be glued as per APA Specification AFG-01 or ASTM D3498 and nailed as per NDS, ICC IBC/IRC code.
6. Refer to appropriate sections of the Specifier Guide for installation guidelines and construction details.
7. **S** = Limited inventory. Please contact your representative to determine quantities.

All information in this document is general in nature and intended for informed tradespeople with the appropriate qualifications and knowledge to properly install floor joists per the manufacturer's specifications and local codes.

The warranty does not extend to products that are misused or neglected, that are subjected to abnormal storage, use or exposure, that have been altered in any way, or that have not been maintained in accordance with published instructions. Products must be handled and installed based on the manufacturer's published instructions.

## Storage and Handling

1. Keep **TRIFORCE**® open joist bundles wrapped until the time of installation to protect them from bad weather.
2. Use wood filler to separate bundles.
3. Always store, stack and handle **TRIFORCE**® open joist vertically and level—never flat.
4. Do not store **TRIFORCE**® open joist in direct contact with the ground.
5. Be cautious when using forklift to avoid damage. If the ground is uneven in the storage area, reduce forklift speed to avoid "bouncing" the load.
6. When handling with a crane, use a spreader to pick up the load, if necessary, to minimize handling stresses. Keep **TRIFORCE**® open joist vertical.
7. Maintain stack height within safe limits.
8. Handling of **TRIFORCE**® open joists with a crane or forklift should be done by lifting from below the bottom of the bundle.
9. Do not stack other material on top of **TRIFORCE**® open joist bundles.
10. Bundle wrap can be slippery, especially when wet or icy. Avoid walking on material.

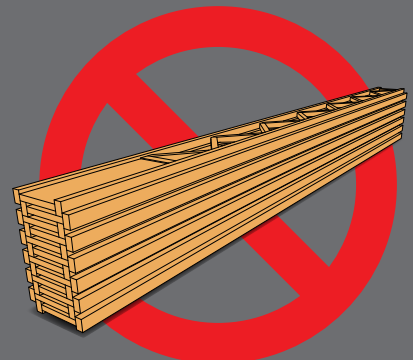
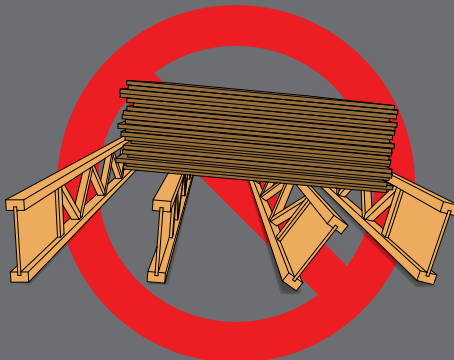
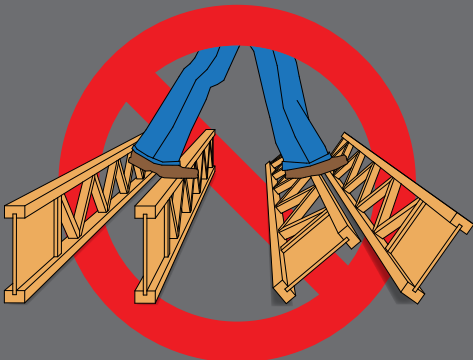
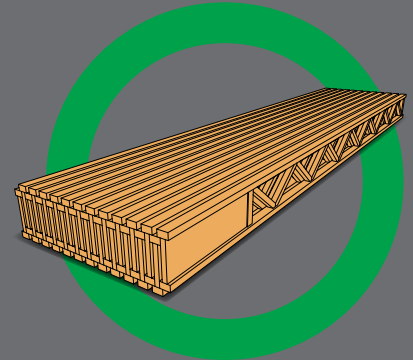
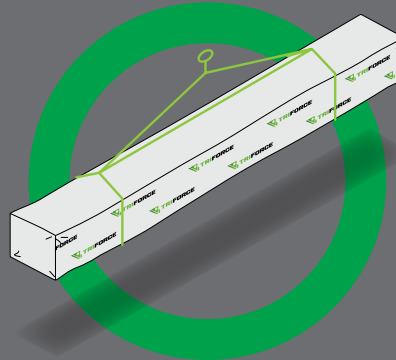
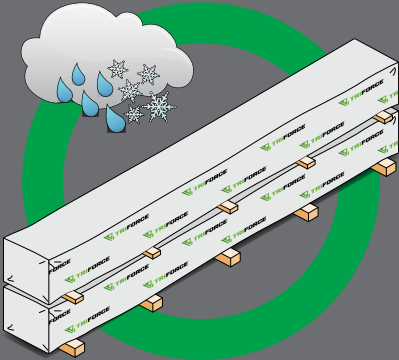

# Installation Instructions

1. Except for trimming the joist length on the OSB end panel, chords should never be cut, drilled or notched.
2. Install **TRIFORCE**® open joist so that top and bottom flanges are within 1/2" of true vertical alignment.
3. Joists must be restrained at the ends to prevent rollover.
4. Apply concentrated loads only on top flanges. Do not suspend concentrated loads from bottom flanges, except for light loads such as ceiling fans or light fixtures.
5. **TRIFORCE**® open joists must be protected from bad weather prior to installation.
6. Joists should be used in dry conditions only.
7. Never install a damaged **TRIFORCE**® open joist.
8. If optional strongbacks are installed, they must be made of dry lumber.
9. End bearing must be a minimum of 1 1/2". Placement Guide may specify longer bearings.
10. To transfer a vertical load applied above the joist to a bearing, it may be necessary to add a rim board, squash blocks or blocking panels.
11. Joists must not be in direct contact with masonry or concrete.
12. **DO NOT WALK ON JOISTS** until properly braced. Serious injury may occur.
13. **DO NOT PILE** construction materials on joists until they are fully installed, braced and have subfloor installed.
14. When nailing into the joist flange, nails must be spaced at least 2 1/2" o.c.
15. Details on the following pages show only the installation requirements specific to **TRIFORCE**® open joists. For other installation requirements, refer to the building code or manufacturers' instructions.
16. Adhesives used for floor systems should comply with ASTM D3498-03 Standard Specification for Field-Gluing Plywood to Lumber Framing for Floor Systems. When gluing the subfloor to the joists, follow the instructions of the adhesive manufacturer.

## Not permitted

Never notch, cut or drill a joist member.

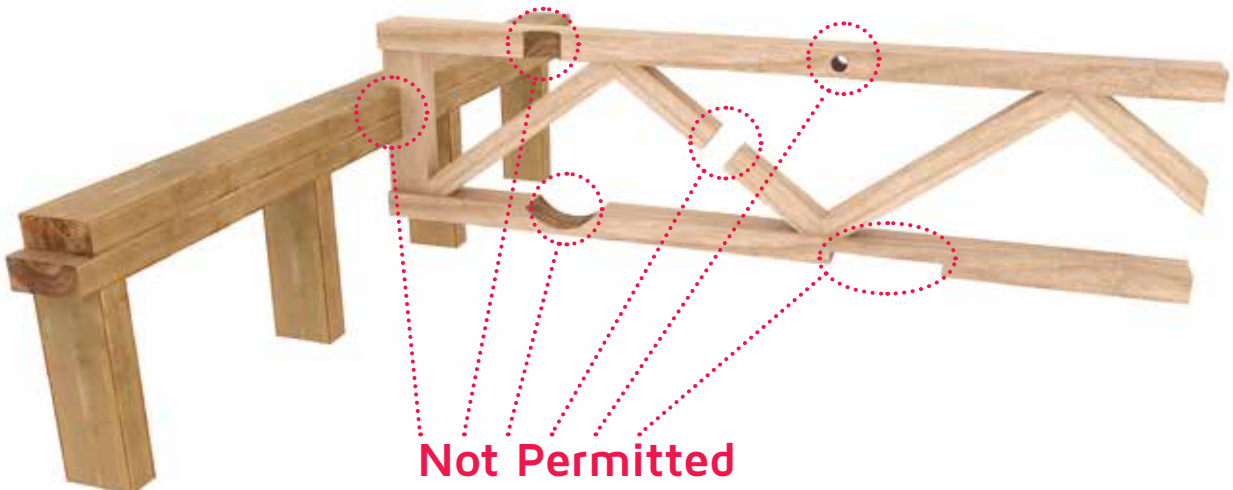

**Not Permitted**

# Standard Details

This section provides standard details for normal framing situations. For loads that are not uniformly distributed and/or for joists supported by bearings other than end bearings, joist capacity must be verified using the manufacturer's Analyzer software.

The project designer and/or general contractor is responsible for determining if standard details apply.

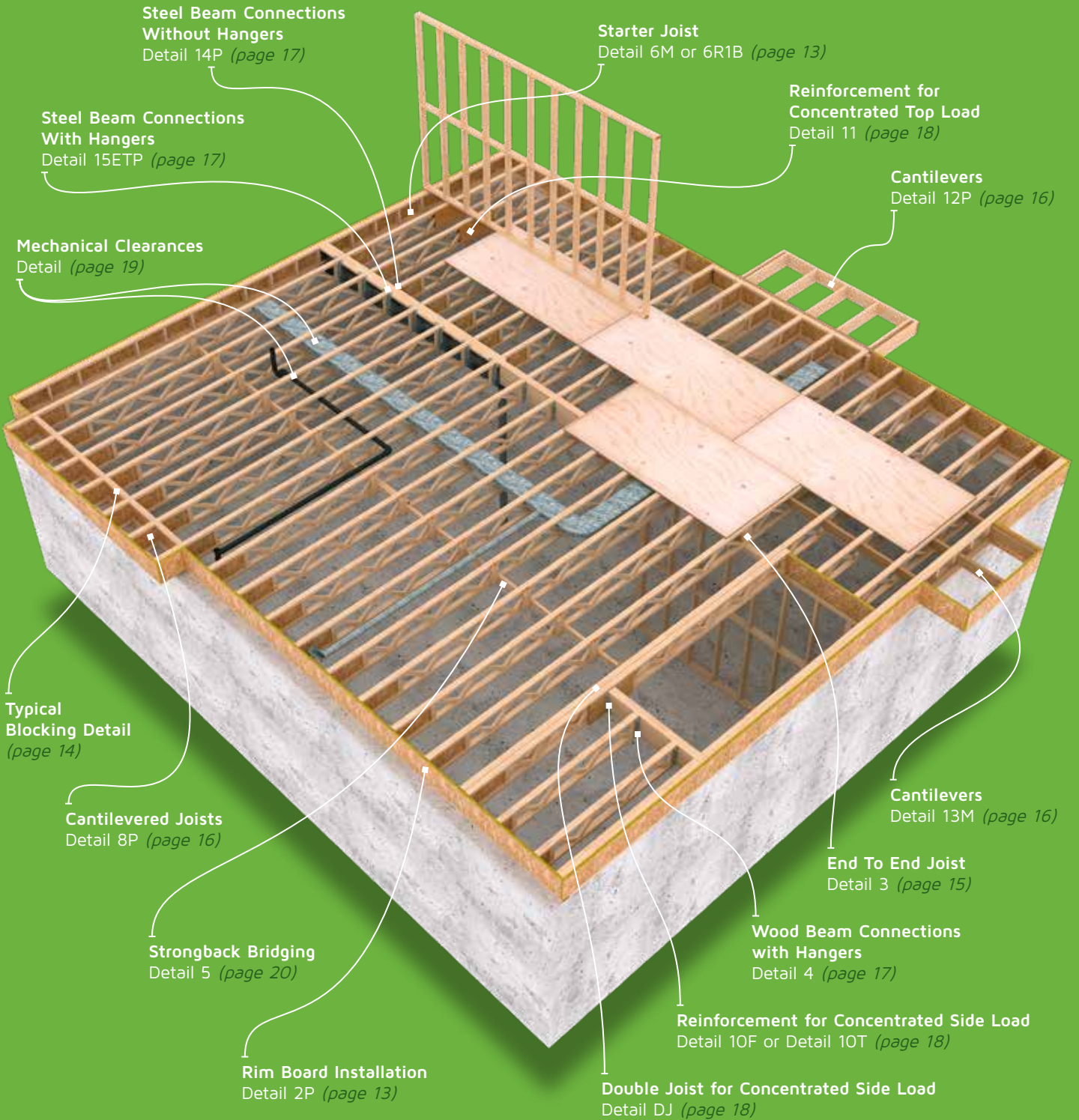

# Rim Board Installation

## Standard Rim Board Sizes

Depth (inches): 11 7/8, 14, 16.



A structural rim board is required when **TRIFORCE**® open joists are installed perpendicular to bearing walls.

**TRIFORCE**® open joists should not be used as solo starter joists on exterior walls.

The vertical and/or horizontal loads to be transferred must be verified using the manufacturer's proprietary capacities.

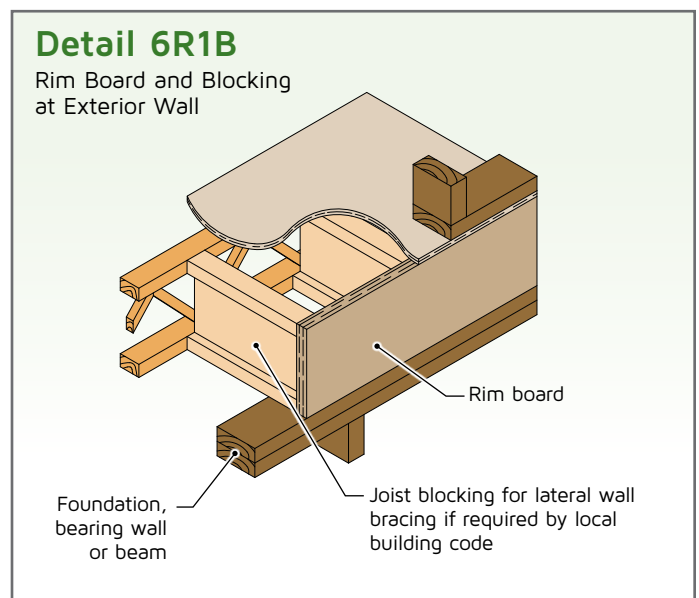
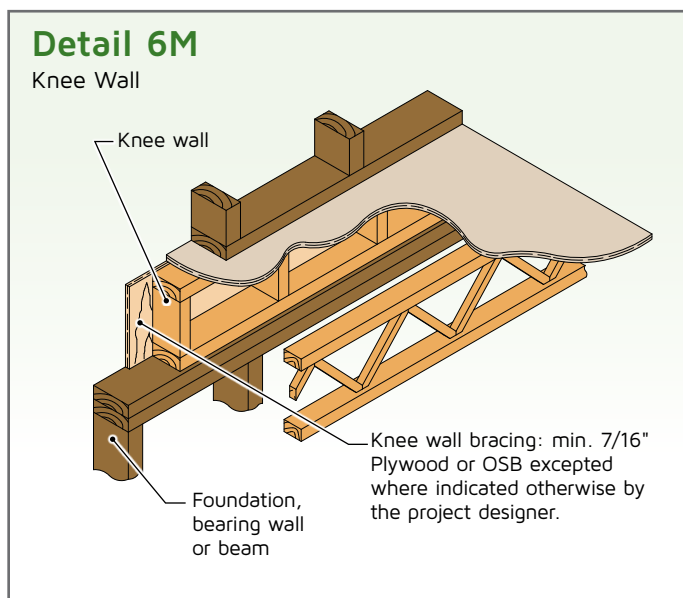
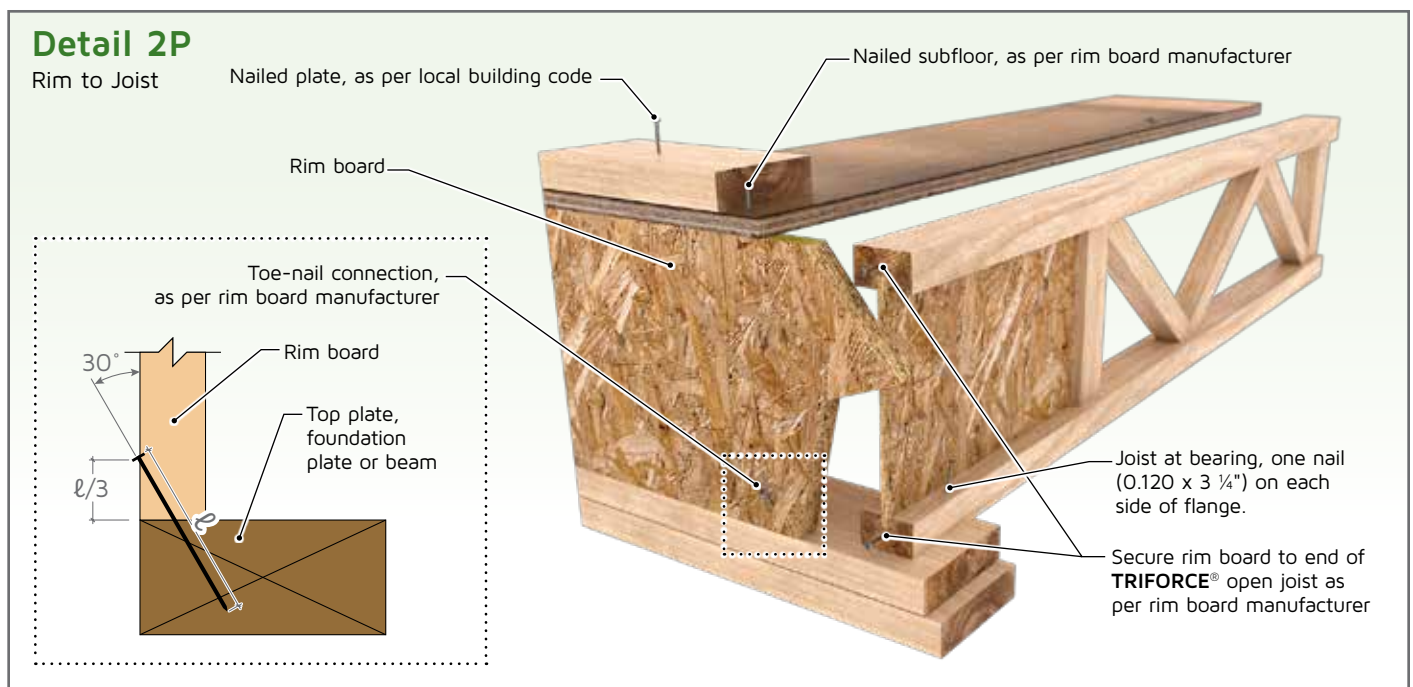

# Typical Blocking Detail

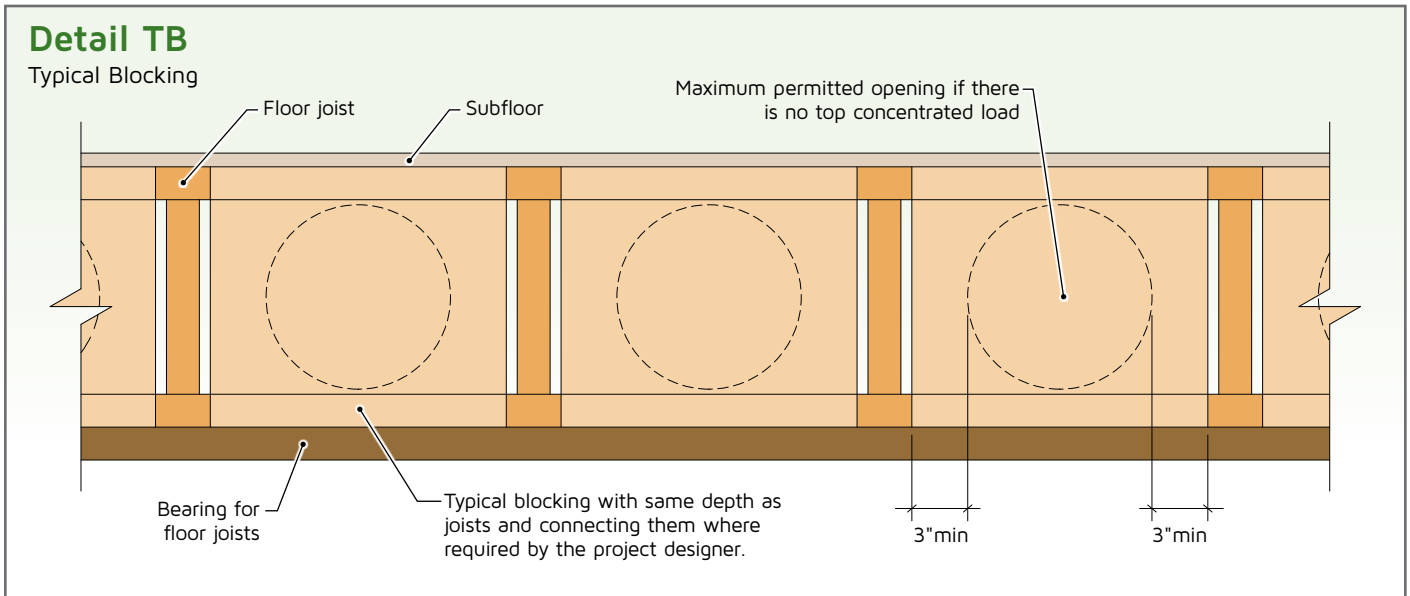

# End To End Joists

Illustrated below

## Detail 3

End To End Joist

Blocking not required between joists for detached one- and two-family dwellings, assigned to Seismic Design Category A, B or C or located where the mapped  $S_s < 0.4g$

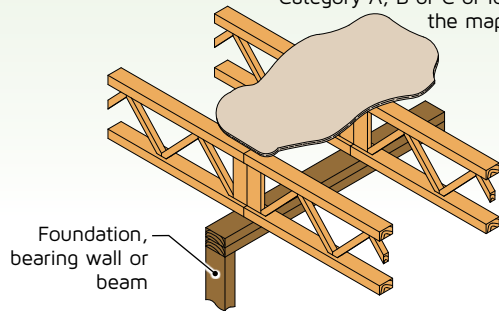

Foundation, bearing wall or beam

## Detail 3B

End to End Joist with Bearing Wall Above

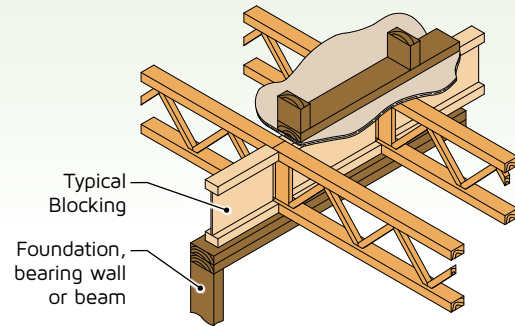

Typical Blocking  
Foundation, bearing wall or beam

## Detail 3P1

End To End Joist

Blocking not required between joists for detached one- and two-family dwellings, assigned to Seismic Design Category A, B or C or located where the mapped  $S_s < 0.4g$

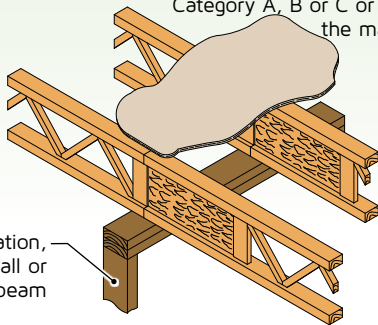

Foundation, bearing wall or beam

## Detail 3P1B

End to End Joist with Bearing Wall Above

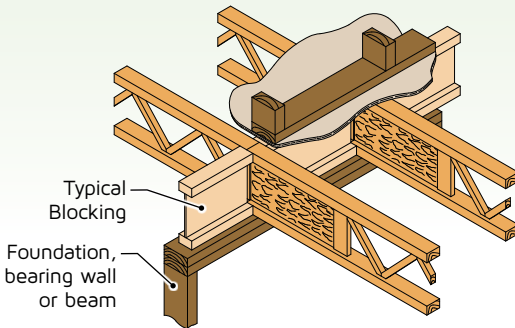

Typical Blocking  
Foundation, bearing wall or beam

## Detail 3P2

End To End Joist

Blocking not required between joists for detached one- and two-family dwellings, assigned to Seismic Design Category A, B or C or located where the mapped  $S_s < 0.4g$

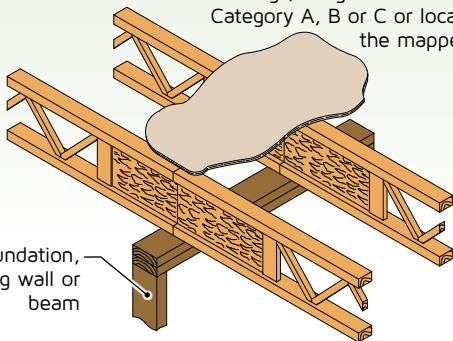

Foundation, bearing wall or beam

## Detail 3P2B

End to End Joist with Bearing Wall Above

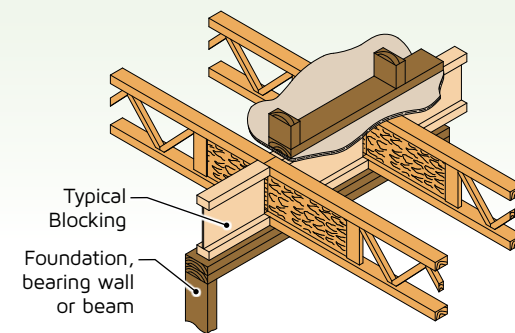

Typical Blocking  
Foundation, bearing wall or beam



# Cantilevered Joists

TRIFORCE® open joists can be cantilevered to support balconies, bays and other design features, subject to certain conditions. Verification of loading using manufacturer's Analyzer software will determine what type of reinforcement is required, if any.



Illustrated below

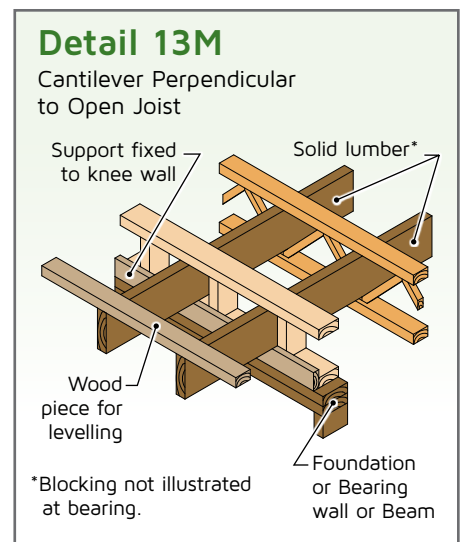
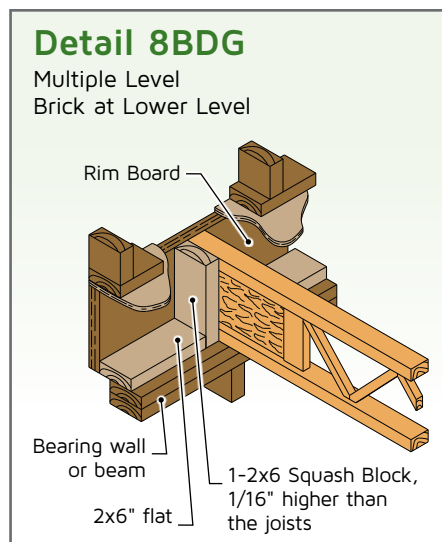
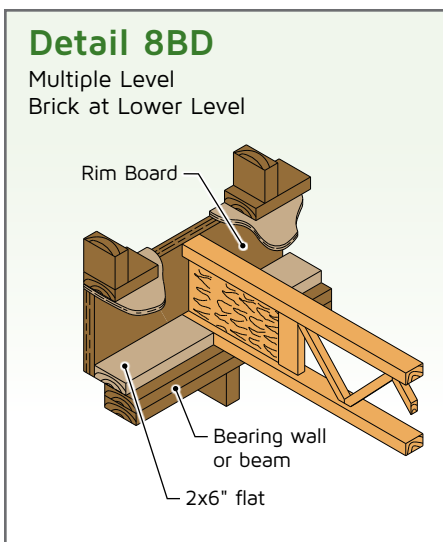
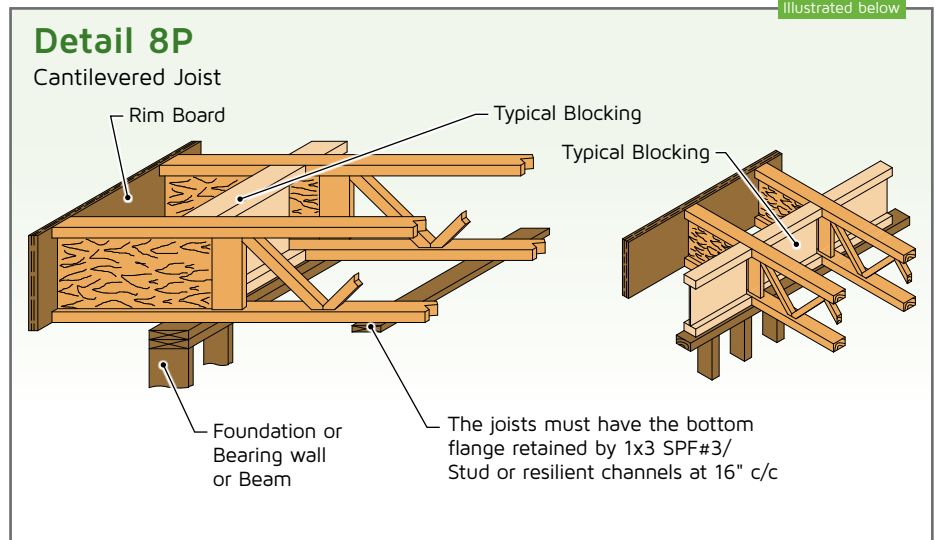
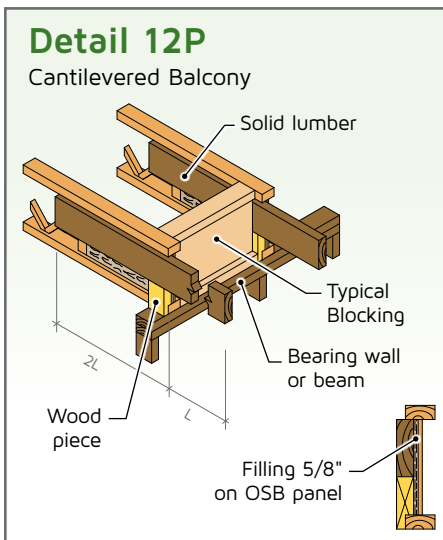

# Wood Beam Connections with Hangers

## Detail 4

Wood Beam Connections with Hangers

\* top mount or face mount hangers

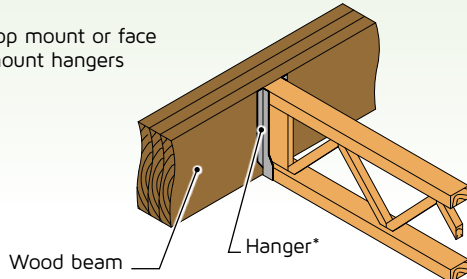

# Steel Beam Connections with Hangers

## Detail 15ETP

Steel Beam Connections With Top Plate and Hanger

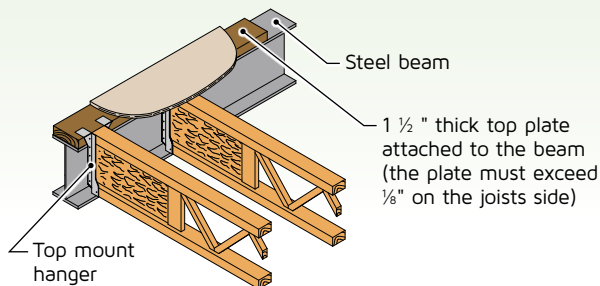

# Steel Beam Connections Without Hangers

## Detail 14P

Steel Beam Bottom Flange Bearing

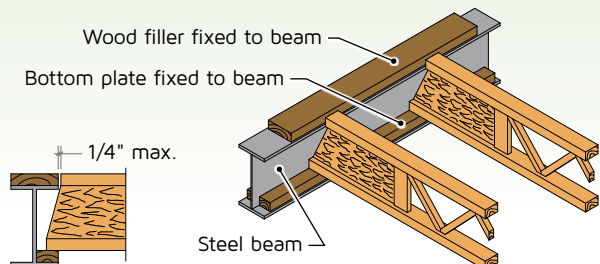

# Doubled Joist for Concentrated Side Load

**Detail DJ**  
Doubled Joist Load Transfer

Point load on the side

Install connectors on the top and bottom chord to transfer from the first ply to the second ply, the load indicated in manufacturer's «Analyzer» software report.



# Reinforcement for a Concentrated Side Load

**Detail 10F**  
Reinforcement for a Concentrated Side Load - Face Mount Hanger

Header

Reinforcements

Header

Reinforcements: See «Reinforcement» section of the Analyzer software's report to have all material requirements (sizes, quantities, etc.)

**Detail 10T**  
Reinforcement for a Concentrated Side Load - Top Mount Hanger

Top Mount Hanger

Header

Reinforcements (may be required): See «Reinforcement» section of the Analyzer software's report to have all material requirements (sizes, quantities, etc.)

# Reinforcement for a Concentrated Top Load Between Two Bearings

**Detail 11**  
Reinforcement for a Concentrated Top Load

Reinforcements (may be required): See «Reinforcement» section of the Analyzer software's report to have all material requirements (sizes, quantities, etc.)



# Mechanical Clearances

Maximum Size of Pipes, Ducts and Cable Trays Through Diagonal Web Members			
Depth	Round D	Square W x H	Rectangular W x L
11 7/8"	7/4"	5 3/4" x 5 3/4"	3" x 13"
14"	8 1/2"	6 1/2" x 6 1/2"	3" x 14", 6" x 8"
16"	9 1/2"	7 1/2" x 7 1/2"	3" x 15"

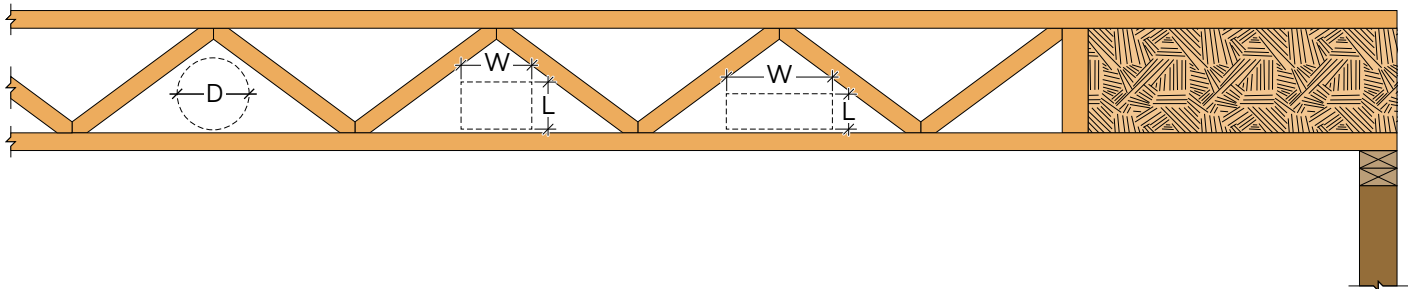

## Openings in the OSB End Panel of a Joist

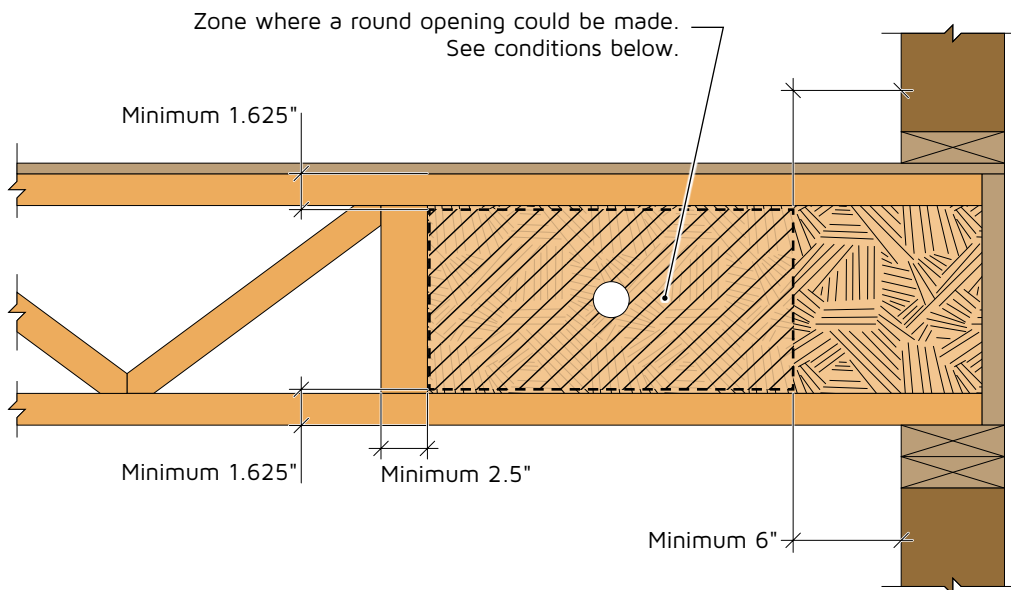

### Conditions:

1. One (1) round hole of 1.5" or less diameter can be made in this zone without any adjustment of the joist capacity.
2. For any other quantity or type of hole, the joist capacity has to be analyzed using **TRIFORCE**® Analyzer software.

# Strongback Bridging

**Strongbacks contribute to floor system performance but are not required by ICC IRC/IBC code.**

Strongbacks must be of dry lumber and installed as close as possible to mid-span as per Detail 5.

Strongbacks can be cut between two joists for ducts or pipes, if needed.

When installed, please refer to Strongback Bridging Table.

## Detail 5

Use gun nails 0.122" x 3.25" or 3" screws to secure strongback at mid span of joist. If two strongbacks are specified, install the second one adjacent to the next closest diagonal web bay.

### Option #1 (Good)

Attached to diagonal web and chord

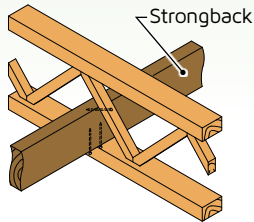

### Option #2 (Better)

Attached to block

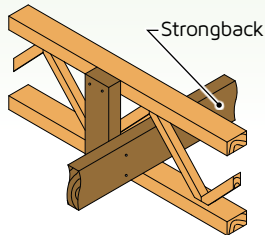

### Strongback Overlap

Joint cover: 32" of length, same thickness and depth as strongbacks, centered on splice.

Strongback

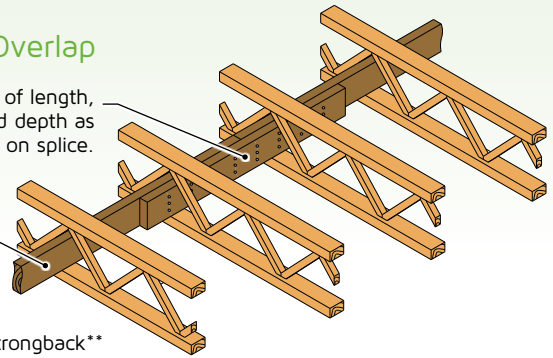

# TRIFORCE® Floor System Performance

## Using Strongbacks to Dampen Vibration

TRIFORCE® open joists are engineered in order to achieve optimum floor system performance. Floor system performance is a subjective measure that varies from one person to another. Expectations of how a floor should feel differ widely according to individuals' reactions.

The two most common performance factors that influence one's opinion of a floor system are deflection and vibration. United States model building codes address only the amount of deflection permitted under loading and do not prescribe vibration standards. While U.S. codes don't address vibration, its effects should be kept in mind by floor system designers.

Adding strongbacks in strategic locations increases floor system performance by distributing loads to adjacent joists. In other words, all elements of the floor including joists, subflooring and strongbacks are working together as a unit. The resulting rigidity effectively dampens vibration.

Even though strongbacks are not required in U.S. applications, they improve performance more effectively than other type of bridging and are recommended for superior floor systems. Best of all, strongbacks can be put in with minimal price and minimal effort.

Strongbacks are more effective if installed properly (see Detail #5). Generally speaking, they are positioned on edge on the joist's bottom chord and run through the floor framing, as close

as possible to mid-span, and they may be spliced. The size and quantity of the strongbacks will vary with spans, joists spacing, depth of the joists, etc. as per Strongback Bridging Table. If required, strongbacks may be cut to allow access for mechanical systems.

Considering strongbacks when specifying floor systems can help to satisfy end-users who carry heightened perceptions and expectations of how a floor should perform.

*Strongback bridging is a major contributor to **Peace of mind underfoot™!***



# Mid-Span Strongback Bridging Table

Strongbacks contribute to floor system performance but are not required by ICC IRC/IBC code.

Joist Spacing		12"	16"	19.2"	24"
Joist Depth	Joist Length	Strongback(s) Quantity and Size			
11 7/8"	8'-0"	None	None	None	None
	10'-0"	None	None	None	None
	12'-0"	None	None	None	None
	14'-0"	None	None	None	None
	16'-0"	None	1- 2x4	1- 2x4	1- 2x4
	18'-0"	1- 2x4	1- 2x6	1- 2x6	1- 2x6
	20'-0"	2- 2x4	1- 2x6	2- 2x6	2- 2x6
	22'-0"	1- 2x6	2- 2x6	2- 2x6	2- 2x6
14"	8'-0"	None	None	None	None
	10'-0"	None	None	None	None
	12'-0"	None	None	None	None
	14'-0"	None	None	None	None
	16'-0"	None	None	None	None
	18'-0"	None	1- 2x6	1- 2x6	1- 2x6
	20'-0"	1- 2x6	1- 2x6	2- 2x6	2- 2x6
	22'-0"	1- 2x6	1- 2x6	2- 2x6	2- 2x6
	24'-0"	1- 2x6	2- 2x6	2- 2x6	2- 2x6
	26'-0"	2- 2x6	2- 2x6	2- 2x6	---
16"	8'-0"	None	None	None	None
	10'-0"	None	None	None	None
	12'-0"	None	None	None	None
	14'-0"	None	None	None	None
	16'-0"	None	None	None	None
	18'-0"	None	None	1- 2x6	1- 2x6
	20'-0"	1- 2x6	1- 2x6	1- 2x6	1- 2x6
	22'-0"	None	1- 2x6	1- 2x6	1- 2x6
	24'-0"	1- 2x6	1- 2x6	2- 2x6	2- 2x6
	26'-0"	1- 2x6	2- 2x6	2- 2x6	2- 2x6
	28'-0"	2- 2x6	2- 2x6	2- 2x6	2- 2x6
	30'-0"	2- 2x6	2- 2x6	2- 2x6	---

# Acoustic Performance

Knowing that sound performance should be considered in early design work, Barrette Structural Distribution has published **TRIFORCE**® open joist acoustic performance ratings as per the summary table below.

## Sound Transmission Class (STC)

Joist Depth	Insulation	Topping <sup>1</sup>	STC
11 7/8"	No	No	46 db
		Yes	52 db
14"	No	No	46 db
		Yes	52 db
16"	No	No	47 db
		Yes	53 db

### Note

1. Use 1.5" normal weight or lightweight concrete or 3/4" gypcrete.

**intertek**

Total Quality. Assured.

To obtain the detailed assemblies and complete acoustic performance data specific to **TRIFORCE**® open joist, check out the Intertek website (<https://bpdirectory.intertek.com>) and look up "Barrette Structural Inc." in the Company field.

# Fire Performance Ratings for Multifamily Buildings

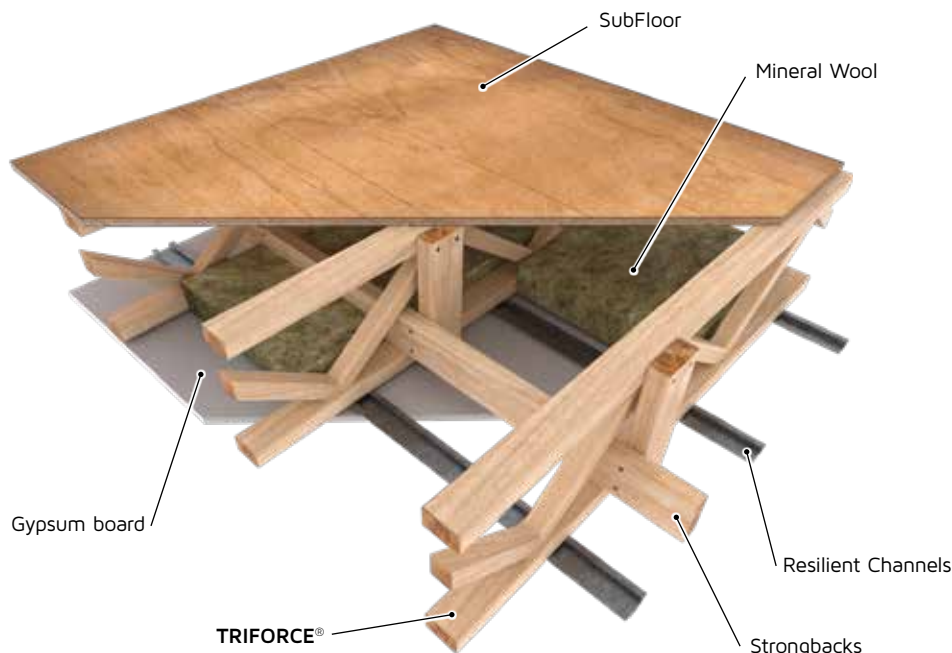

**intertek**

Total Quality. Assured.

**TRIFORCE**® open joist fire-rated assemblies are listed in the Intertek Directory of Building Components.

Check out the Intertek website (<https://bpdirectory.intertek.com>) and look up "Barrette Structural Inc." in the **Company** field.

# Fire Performance Ratings for Multifamily Buildings

## Summary Table

Intertek Design Number	BS/SFWT 45-01	BS/SFWT 60-01	BS/SFWT 60-02	BS/SFWT 60-03	BS/SFWT 60-04	BS/SFWT 60-05A	BS/SFWT 60-05B	BS/SFWT 60-11	BS/SFWT 90-01	BS/SFWT 120-01
Fire Rating Time	45 minutes	60 minutes	60 minutes	60 minutes	60 minutes	60 minutes	60 minutes	60 minutes	90 minutes	120 minutes
Floor Topping	Optional <sup>(1)</sup>	Optional <sup>(1)</sup>	Optional <sup>(1)</sup>	Optional <sup>(1)</sup>	Optional <sup>(1)</sup>	No	Yes <sup>(2)</sup>	Yes <sup>(2)</sup>	Optional <sup>(1)</sup>	Optional <sup>(1)</sup>
Floor Sheathing	19/32" (5/8)	19/32" (5/8)	19/32" (5/8)	19/32" (5/8)	23/32" (3/4)	2 x 23/32" (3/4)	23/32" (3/4)	23/32" (3/4)	19/32" (5/8)	19/32" (5/8)
Roof Sheathing	15/32" (1/2)	15/32" (1/2)	15/32" (1/2)	15/32" (1/2)	15/32" (1/2)	N/A	N/A	N/A	15/32" (1/2)	15/32" (1/2)
TRIFORCE® Open Joist	Top and bottom chord made of 2x3 or 2x4	Top and bottom chord made of 2x3 or 2x4	Top and bottom chord made of 2x4	Top and bottom chord made of 2x3 or 2x4	Top and bottom chord made of 2x3 or 2x4	Top and bottom chord made of 2x3 or 2x4	Top and bottom chord made of 2x3 or 2x4	Top and bottom chord made of 2x3 or 2x4	Top and bottom chord made of 2x3 or 2x4	Top and bottom chord made of 2x3 or 2x4
Min. Depth	9,5"	9,5"	9,5"	9,5"	9,5"	9,5"	9,5"	9,5"	9,5"	9,5"
Max. Spacing	24" o.c.	24" o.c.	24" o.c.	24" o.c.	24" o.c.	24" o.c.	24" o.c.	24" o.c.	24" o.c.	24" o.c.
Strongback Bridging	Optional <sup>(1)</sup>	Optional <sup>(1)</sup>	Optional <sup>(1)</sup>	Optional <sup>(1)</sup>	Optional <sup>(1)</sup>	Installed as per Detail 5 and Strongback Bridging Table	Installed as per Detail 5 and Strongback Bridging Table	Installed as per Detail 5 and Strongback Bridging Table	Optional <sup>(1)</sup>	Optional <sup>(1)</sup>
Insulation	Optional <sup>(1)</sup>	Optional <sup>(1)</sup>	1-1/2" - 2.5 pcf of mineral wool	2" - 3.5 pcf of mineral wool	1" - 6 pcf of mineral wool	3" - 2.5 pcf of mineral wool	3" - 2.5 pcf of mineral wool	3" - 2.5 pcf of mineral wool	1-1/2" - 2.5 pcf of mineral wool	Optional <sup>(1)</sup>
Setting Strip	No	Optional <sup>(1)</sup>	Optional <sup>(1)</sup>	Min. 1x4	No	No	No	No	No	No
Supplementary Uncoupling System	No	No	No	No	No	No	No	GenieClip® RST	No	No
Channels Type	Resilient	Optional <sup>(1)</sup>	Resilient	Resilient	Resilient	Resilient	Resilient	Steel	Resilient	Resilient
Spacing	16 in o.c.	Optional <sup>(1)</sup>	16 in o.c.	16 in o.c.	24 in o.c.	16 in o.c.	16 in o.c.	16 in o.c.	12 in o.c.	16 in o.c.
Gypsum Board	1 x 5/8" Type X	2 x 1/2" Type X	1 x 5/8" Type C	1 x 5/8" Type C	1 x 1/2" Type C	1 x 5/8" Type C	1 x 5/8" Type C	1 x 5/8" Type C	2 x 5/8" Type C	3 x 5/8" Type C

1. Either with any type or nothing.
2. With an authorized material per Intertek fire resistant listing for Barrette Structural Inc.



Total Quality. Assured.

Intertek-approved fire-resistant assemblies SPEC ID: 35685 standard

<https://bpdirectory.intertek.com>

Look up "Barrette Structural Inc." in the Company field.

# Fire Performance for Residential Buildings with Unfinished Ceilings

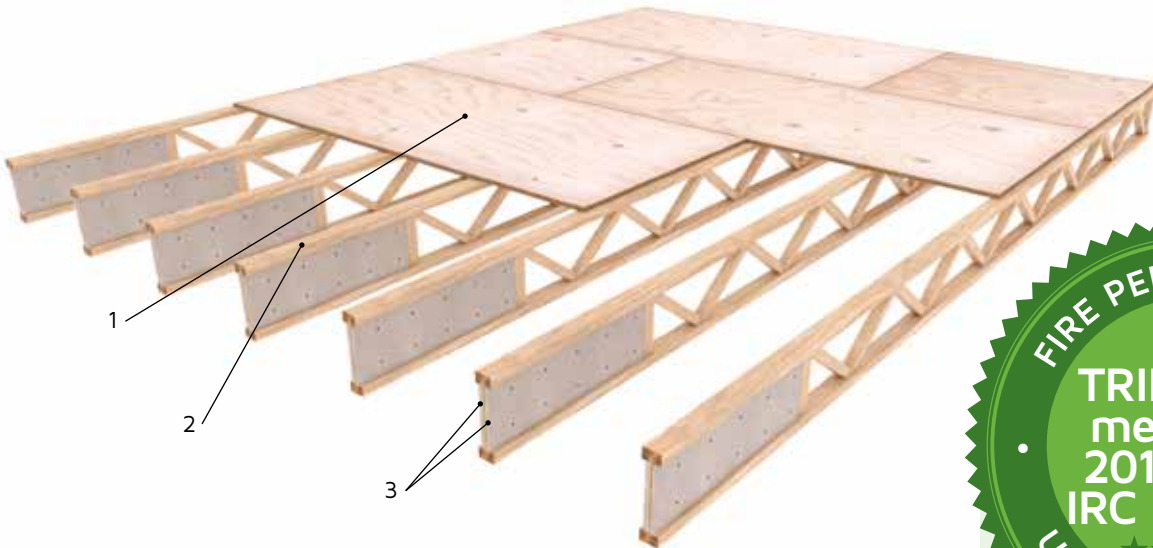

## In compliance with Exception 4 to Section R302.13 of the 2018 / 2021 IRC

TRIFORCE® open joist has been evaluated for equivalent fire-resistant construction to 2-inch-by-10-inch nominal dimension lumber in accordance with Exception 4 to Section R302.13 of the 2018 / 2021 International Residential Code (Section R501.3 of the 2012 International Residential Code), when installed as follow:

### 1-Floor sheathing:

Materials and installation shall be in accordance with section R503 of the International Residential Code.

### 2-TRIFORCE® open joist:

Equivalent performance and qualification as Exception 4 is certified in IAPMO UES ER-539.

### 3-Trimmmable end protection:

TRIFORCE® open joist to be clad with minimum 1/2" unrated gypsum board or 19/32" wood structural panel fully covering both faces of the 3/8" OSB end

panel fastened with 1" nails or screws at 6" o.c. with 2" edge spacing. See Detail A.

3/8" x 1" x 15 or 16 gauge staples may be substituted for nails or screws and shall be installed on both faces with two rows of staples at 6" o.c. with 2" edge spacing.

If cladding cannot be installed using the fastener options above, it may be attached with a 1/4" to 3/8" bead in a "Z pattern" of PL400 structural adhesive (or equivalent) per the manufacturer's instructions.



## Uniform ES

Accredited by the American National Standards Institute (ANSI) and the Standards Council of Canada (SCC)



See the TRIFORCE® evaluation report at: [www.iapmoes.org/EvaluationReports](http://www.iapmoes.org/EvaluationReports)

### Detail A: TRIFORCE® trimmmable end protection

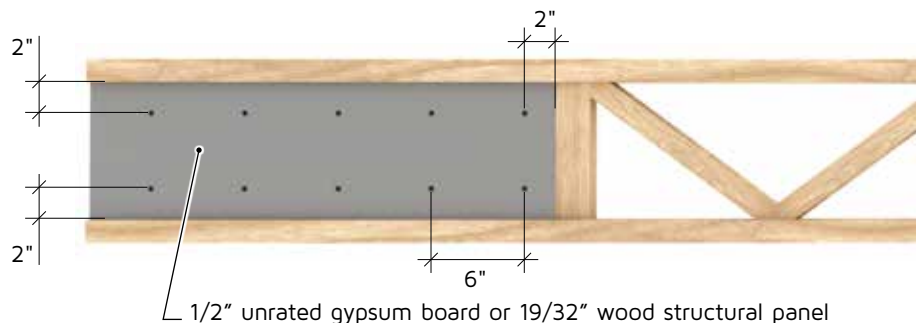

# TRIFORCE® Analyzer Software

Barrette Structural Distribution has designed a cutting-edge yet easy-to-use software that can adjust to all our clients' needs. It includes detailed engineering analysis.

Our solutions will help your company at every stage, from whole-floor analysis to individual member sizing.

TRIFORCE® Analyzer is a member-sizing software program that engineers, architects and designers can use to size **TRIFORCE®** open joist. TRIFORCE® Analyzer is available as standalone software. To download it, visit the Analyzer section of our website at [www.openjoisttriforce.com](http://www.openjoisttriforce.com).

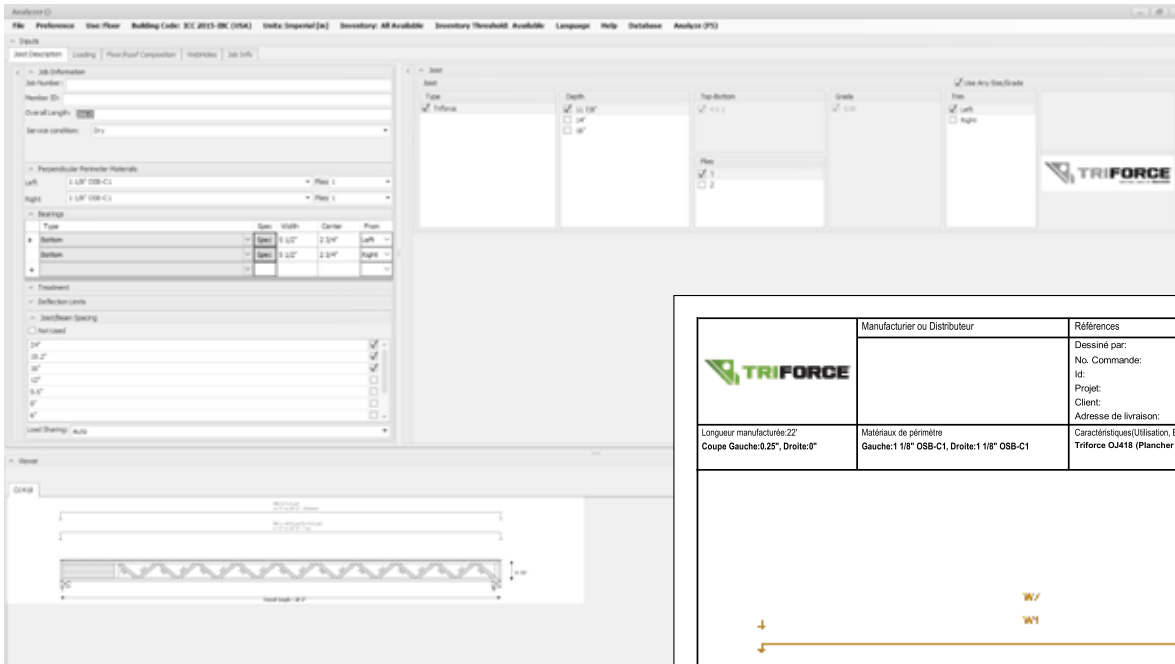

	Manufacturier ou Distributeur	Références Dessiné par: No. Commande: Id: Projet: Client: Adresse de livraison:									
	Longueur manufacturée: 22' Coupe Gauche: 0.25°, Droite: 0°	Matériaux de périmètre Gauche: 1 1/8" OSB-C1, Droite: 1 1/8" OSB-C1	Caractéristiques (Utilisation, Epaisseur, Semelles, Plis, Espacement) Triforce OJ418 (Plancher - Solive, 11 7/8", 4 X 2, 1 pli, 16" c/c)								
LOADING											
Dessus Roll(θ)=0° Pitch(θ)=0°											
Lbl	Nb	@ c/c	Type	X1	X2	Y	Z	θ	L	Lp	Loads
W1	1	-	Surf	0"	22' 2"	-	-	-	22' 2"	1' 4"	(psf): L=40, D=15
Dessous Roll(θ)=180° Pitch(θ)=0°											
Lbl	Nb	@ c/c	Type	X1	X2	Y	Z	θ	L	Lp	Loads
W2	1	-	Surf	0"	22' 2"	-	-	-	22' 2"	1' 4"	(psf): D=5
CAS DE CHARGEMENT APPLIQUÉS AUX CALCULS DE RÉSISTANCE											
CC1 : D CC2 : D+L LÉGENDE: L: Surcharge d'usage, D: Permanente.											
RÉACTIONS NON-PONDÉRÉES											
Appui	G		D								
	Min	Max	Min	Max							
Partiel	0	1	0	1							
Soulèvement	0	1	0	1							
Permanente	295.56	295.56	295.56	295.56							
Surcharge d'usage	0	591.11	0	591.11							
Date: 2018-05-24 STRUCTURAL ANALYZER Version : 1.7.1694 IMPERIAL USA Page: 1 de 2											

# Single Joist Connectors

These are a few of the most commonly used hangers for the assembly of floor systems with **TRIFORCE®** open joist. Contact your local supplier to purchase these hangers or to find out more about their properties and limitations. The most popular brands include Simpson StrongTie and MiTek USP.

- Face mount hanger
- Top flange hanger
- Skewed 45° hanger (right or left)

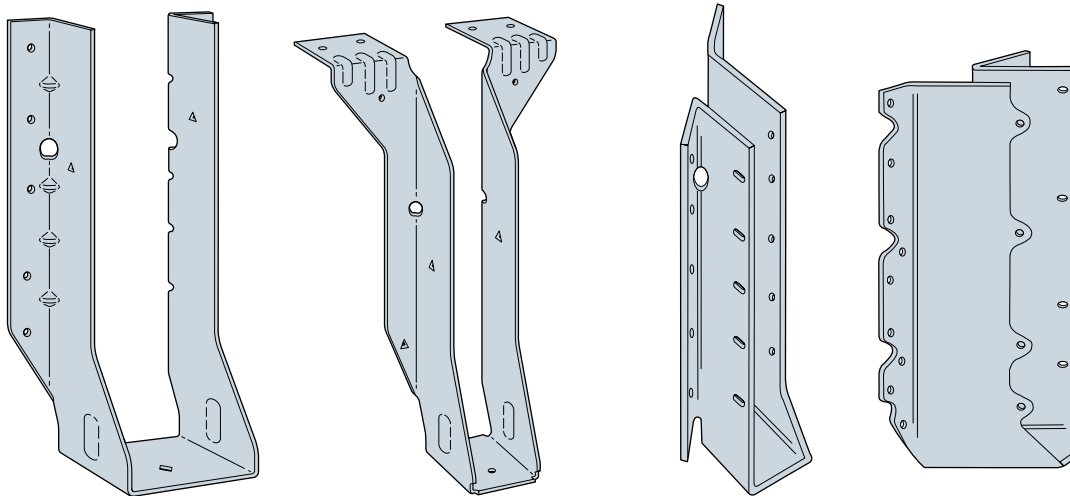

## Wood Filler for a Single Joist with Hanger

Only required if the hanger does not provide lateral support for the joist's top chord.

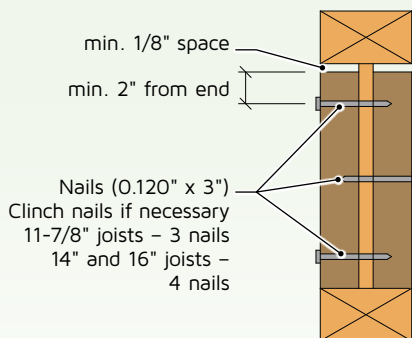

### Joists with 3X2 chords

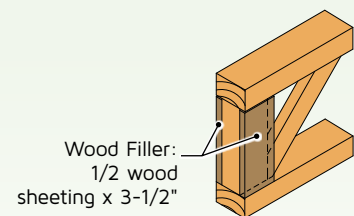
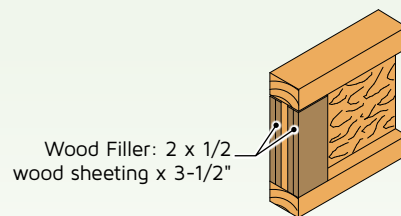

### Joists with 4X2 chords

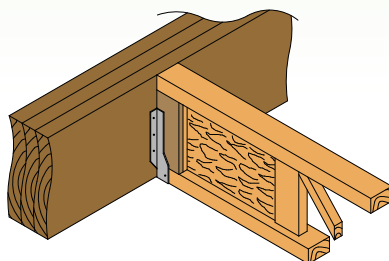
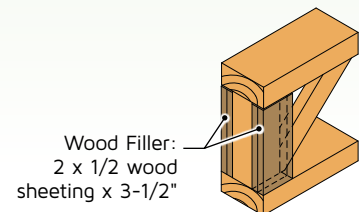
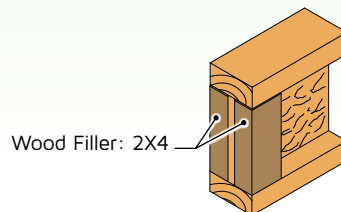

# Double Joist Connectors

These are a few of the most commonly used hangers for the assembly of floor systems with **TRIFORCE**® open joist. Contact your local supplier to purchase these hangers or to find out more about their properties and limitations. The most popular brands include Simpson StrongTie and MiTek USP.

- Face mount hanger
- Top flange hanger
- Skewed 45° hanger (right or left)

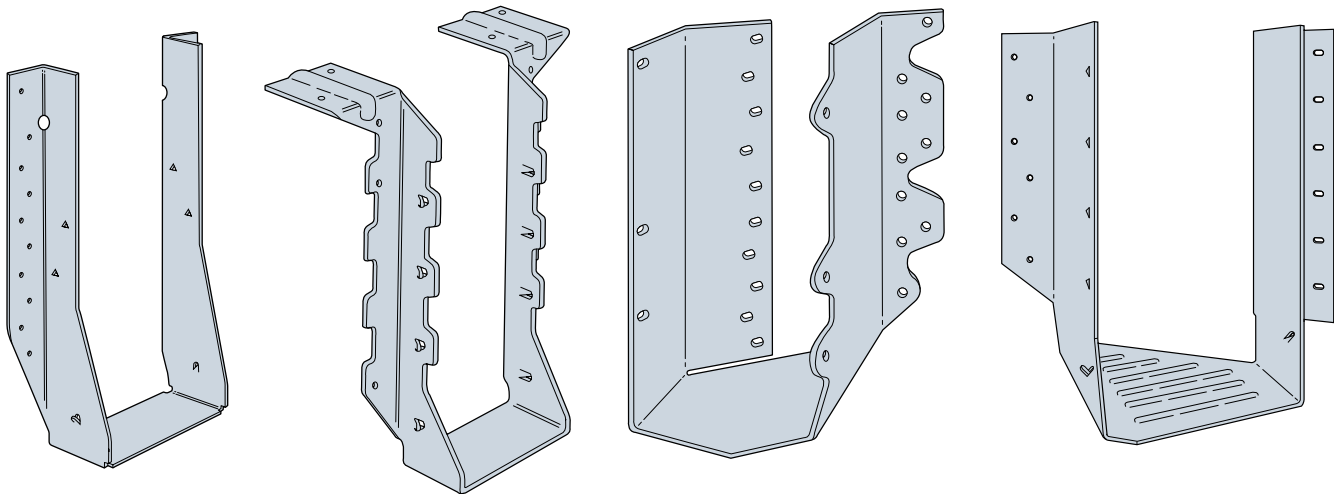

## Wood Filler for a Double Joist with Hanger

Only required if the hanger does not provide lateral support for the joist's top chord.

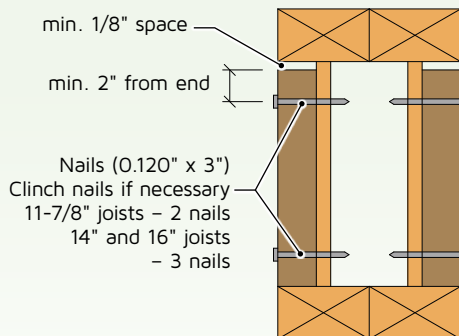

### Joists with 3X2 chords

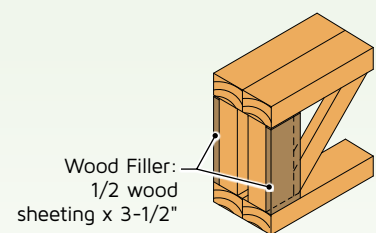
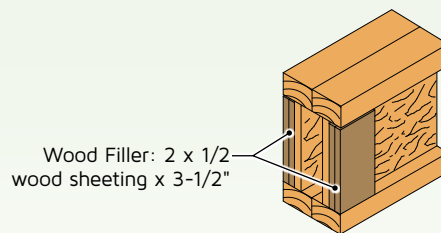

### Joists with 4X2 chords

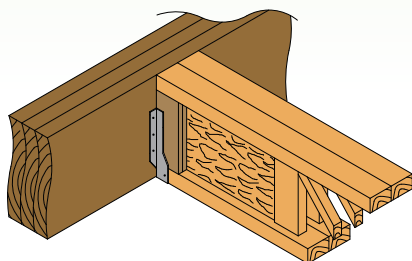
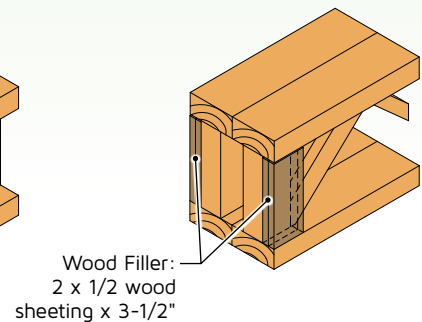
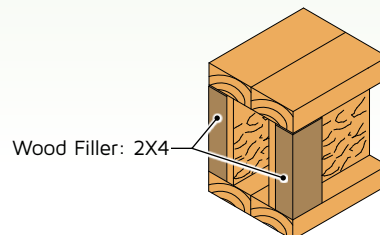

# Warranty



## Barrette Structural Distribution Inc. Manufacturer's Product Warranty

Products manufactured by Barrette Structural Distribution Inc. (hereafter: "Barrette Structural Distribution") are guaranteed for the life of the structure against all manufacturing defects and faulty materials, for which manufacturer's original warranty applies.

This limited lifetime warranty is applicable if the products manufactured by Barrette Structural Distribution have been correctly stored, protected from climatic conditions such as sunlight, humidity, rain or wind, installed and used in accordance with the relevant product manufacturer's guidelines and applicable standards and codes, either as floor joists or roof trusses, whichever is the case.

This warranty does not cover perceived problems of design or defects caused by:

- prolonged exposure to water or climatic conditions, including but not limited to, fire, flooding, natural disasters or any other cause beyond the control of Barrette Structural Distribution;
- defective structure due to several factors, including but not limited to, poor construction practices, and incorrect installation methods;
- damage to the structure before, during or after installation;
- failure to respect installation instructions, current building codes and norms, and best practices installation techniques;
- the modification of joists or roof trusses after the proposed original installation;
- the presence of mold, spore, rot or termites or any other element likely to degrade the installed product;
- the application of a preservative treatment or any other coating not approved by Barrette Structural Distribution;
- defective ventilation, repeated exposure to water or humid conditions;
- excessive loads or tension not allowed for by Barrette Structural Distribution or abnormal or non-compliant use of the product contrary to the use to which it was intended or use contrary to Barrette Structural Distribution's guidance and/or instructions, or under abnormal conditions of use or under unforeseeable conditions by Barrette Structural Distribution.

IN THE CASE OF PROBLEMS WITH MANUFACTURING FAULTS COVERED BY THIS WARRANTY, BARRETTE STRUCTURAL DISTRIBUTION WILL PAY REASONABLE COSTS FOR LABOUR AND MATERIALS TO REPAIR OR REPLACE ONLY THE PRODUCT UNDER ITS WARRANTY. THESE COSTS MUST NOT EXCEED BY MORE THAN THREE TIMES THE INITIAL PURCHASE COST OF THE PRODUCT INVOLVED IN THE CLAIM. THESE REMEDIES ARE THE SOLE AND EXCLUSIVE REMEDIES FOR ANY BREACH OF WARRANTY. TO THE MAXIMUM EXTENT PERMITTED BY LAW, BARRETTE STRUCTURAL DISTRIBUTION IS NOT RESPONSIBLE FOR ANY DIRECT, SPECIAL, INCIDENTAL, OR CONSEQUENTIAL DAMAGES RESULTING FROM ANY BREACH OF WARRANTY.

IN THE EVENT OF A CLAIM, THE RESPONSIBILITY OF BARRETTE STRUCTURAL DISTRIBUTION IS LIMITED TO THAT WHICH HAS BEEN OUTLINED IN THIS WARRANTY. BARRETTE STRUCTURAL DISTRIBUTION MAY NOT BE HELD RESPONSIBLE FOR ANY OTHER DAMAGE WHATSOEVER. THIS WARRANTY SUPERSEDES ALL OTHER WARRANTIES AND REPRESENTATIONS ABOUT THE PRODUCT.

Warranty claims must be made in writing as soon as the manufacturing defect is discovered and in any case not more than thirty (30) days after such discovery.

BARRETTE STRUCTURAL DISTRIBUTION INC.  
555, rang Saint-Malo, Trois-Rivières (Québec) G8V 0A8 CANADA

*To obtain further information, please contact your representative.*

**Peace of mind underfoot™**  
[www.openjoisttriforce.com](http://www.openjoisttriforce.com)